

PB A 1500 F -5 -□

① ② ③ ④ ⑤ ⑥



UL US CE RoHS

- ① Series name
- ② Single output
- ③ Output wattage
- ④ Universal input
- ⑤ Output voltage
- ⑥ Optional *6
- C :with Coating
- G :Low leakage current
- U :Operation stop voltage is set at a lower value
- F1 :With Long-Life fan
- F3 :Reverse air exhaust type
- F4 :Low speed fan

Refer to instruction manual 7.1.

MODEL	PBA1500F-3R3	PBA1500F-5	PBA1500F-7R5	PBA1500F-12	PBA1500F-15	PBA1500F-24	PBA1500F-36	PBA1500F-48	
MAX OUTPUT WATTAGE[W]	990	1500	1500	1500	1500	1680	1692	1680	
DC OUTPUT	ACIN 100V	3.3V 300A	5V 300A	7.5V 200A	12V 125A	15V 100A	24V 65A	36V 42A	48V 32A
	ACIN 200V *6	3.3V 300A	5V 300A	7.5V 200A	12V 125A	15V 100A	24V 70(105)A	36V 47(70)A	48V 35A

SPECIFICATIONS

	MODEL	PBA1500F-3R3	PBA1500F-5	PBA1500F-7R5	PBA1500F-12	PBA1500F-15	PBA1500F-24	PBA1500F-36	PBA1500F-48	
INPUT	VOLTAGE[V]	AC85 - 264 1 φ or DC120 - 370 (AC50 or DC70 Please refer to the instruction manual 7. option *5)								
	CURRENT[A]	ACIN 100V	15typ	19typ						
		ACIN 200V	8typ	10typ						
	FREQUENCY[Hz]	50/60 (47 - 63)								
	EFFICIENCY[%]	ACIN 100V	72typ	77typ	81typ	81typ	83typ	84typ	84typ	84typ
		ACIN 200V	75typ	81typ	83typ	84typ	86typ	87typ	87typ	87typ
	POWER FACTOR	ACIN 100V	0.98typ (Io=100%)							
		ACIN 200V	0.95typ (Io=100%)							
	INRUSH CURRENT[A]	ACIN 100V	20/40typ (Io=100%) (Primary inrush current /Secondary inrush current) (More than 10 sec. to re-start)							
		ACIN 200V	40/40typ (Io=100%) (Primary inrush current /Secondary inrush current) (More than 10 sec. to re-start)							
LEAKAGE CURRENT[ma]	0.9/1.5max (ACIN 100V/240V 60Hz, Io=100%, According to IEC60950-1, DENAN)									
OUTPUT	VOLTAGE[V]	3.3	5	7.5	12	15	24	36	48	
	CURRENT[A]	ACIN 100V	300	300	200	125	100	65	42	32
		ACIN 200V *6	300	300	200	125	100	70(105)	47(70)	35
	LINE REGULATION[mV]	20max	20max	36max	48max	60max	96max	144max	192max	
	LOAD REGULATION[mV]	40max	40max	60max	100max	120max	150max	150max	300max	
	RIPPLE[mVp-p]	0 to +50°C *1	80max	80max	120max	120max	120max	120max	150max	150max
		-20 - 0°C *1	140max	140max	160max	160max	160max	160max	160max	400max
	RIPPLE NOISE[mVp-p]	0 to +50°C *1	120max	120max	150max	150max	150max	150max	200max	200max
		-20 - 0°C *1	160max	160max	180max	180max	180max	180max	240max	500max
	TEMPERATURE REGULATION[mV]	0 to +50°C *1	40max	50max	75max	120max	150max	240max	360max	480max
		-20 to +30°C *1	60max	75max	120max	180max	180max	290max	440max	600max
	DRIFT[mV]	*2	12max	20max	30max	48max	60max	96max	144max	192max
	START-UP TIME[ms]	600typ(ACIN 100/200V, Io=100%)								
	HOLD-UP TIME[ms]	20typ (ACIN 100/200V, Io=100%)								
	OUTPUT VOLTAGE ADJUSTMENT RANGE[V]	2.64 - 3.96	3.96 - 6.00	5.25 - 8.25	8.25 - 13.20	10.50 - 16.50	16.50 - 26.40	25.20 - 39.60	38.40 - 56.00	
OUTPUT VOLTAGE SETTING[V]	3.30 - 3.40	5.00 - 5.15	7.50 - 7.80	12.00 - 12.48	15.00 - 15.60	24.00 - 24.96	36.00 - 37.44	48.00 - 49.92		
PROTECTION CIRCUIT AND OTHERS	OVERCURRENT PROTECTION	Works over 105% of rated current or 101% of peak current and recovers automatically								
	OVERVOLTAGE PROTECTION[V] *4	Vo+0.66 - 1.32	Vo+1.0 - 2.0	Vo+1.5 - 3.0	Vo+2.4 - 4.8	Vo+3.0 - 6.0	Vo+4.8 - 9.6	Vo+7.2 - 14.4	Vo+4.8 - 12.0	
	OPERATING INDICATION	LED (Green)								
	REMOTE SENSING	Provided								
	REMOTE ON/OFF	Provided								
ISOLATION	INPUT-OUTPUT · RC	AC3.000V 1minute, Cutoff current = 25mA, DC500V 50MΩmin (At Room Temperature)								
	INPUT-FG	AC2.000V 1minute, Cutoff current = 25mA, DC500V 50MΩmin (At Room Temperature)								
	OUTPUT · RC · AUX-FG	AC500V 1minute, Cutoff current = 100mA, DC500V 50MΩmin (At Room Temperature)								
	OUTPUT-RC · AUX	AC500V 1minute, Cutoff current = 100mA, DC500V 50MΩmin (At Room Temperature)								
ENVIRONMENT	OPERATING TEMP.,HUMID.AND ALTITUDE	-20 to +71°C (Required Derating), 20 - 90%RH (Non condensing) 3,000m (10,000feet) max								
	STORAGE TEMP.,HUMID.AND ALTITUDE	-20 to +75°C, 20 - 90%RH (Non condensing) 9,000m (30,000feet) max								
	VIBRATION	10 - 55Hz, 19.6m/s ² (2G), 3minutes period, 60minutes each along X, Y and Z axis								
	IMPACT	196.1m/s ² (20G), 11ms, once each X, Y and Z axis								
SAFETY AND NOISE REGULATIONS	AGENCY APPROVALS (At only AC input)	UL60950-1, C-UL(CSA60950-1), EN60950-1, EN50178 Complies with DEN-AN								
	CONDUCTED NOISE	Complies with FCC Part15 classB, VCCI-B, CISPR22-B, EN55011-B, EN55022-B, additional noise filter required for meeting class B								
	CE MARKING	Low Voltage Directive, EMC Directive								
	HARMONIC ATTENUATOR	Complies with IEC61000-3-2								
OTHERS	CASE SIZE/WEIGHT	178 x 61 x 268mm (without terminal block and screw) (W x H x D) /3.4kg max								
	COOLING METHOD	Forced cooling (internal fan)								

*1 Measured by 20MHz oscilloscope or Ripple-Noise meter(equivalent to KEISOKU-GIKEN :RM101).
Ripple and ripple noise is measured on measuring board with capacitor of 22 μF within 150mm from the output terminal.
*2 Drift is the change in DC output for an eight hour period after a half-hour warm-up at 25°C.
*3 () means peak current. Peak loading for 10s. And Duty 35% max, refer to Instruction manual

in detail.
*4 Overvoltage protection circuit to follow to output voltage setting.
*5 Derating is required. Consult us for details.
* A sound may occur from power supply at pulse loading.
*6 Please contact us about safety approvals for the model with option.

Block diagram

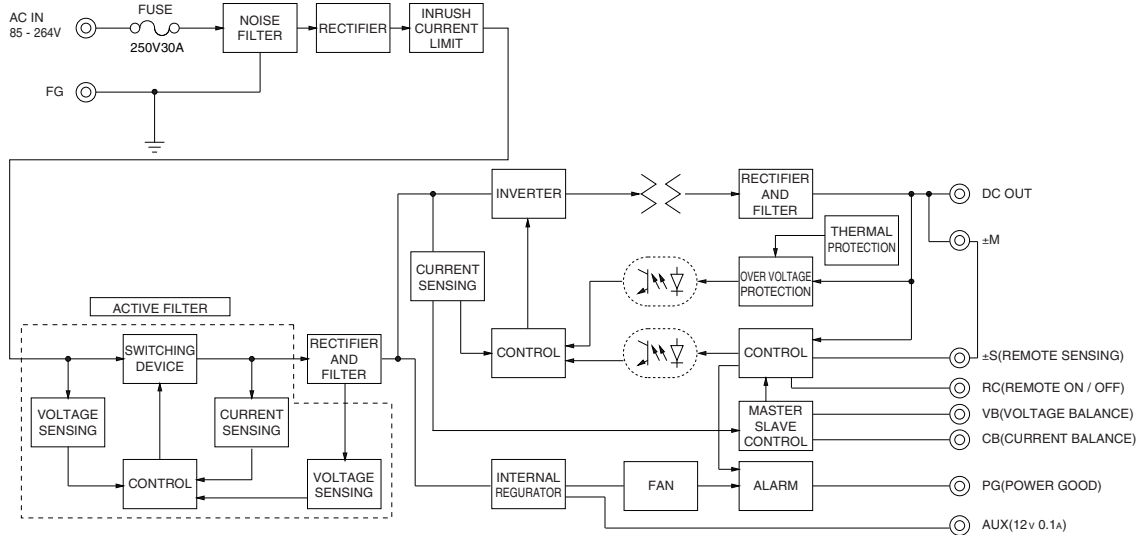

External view

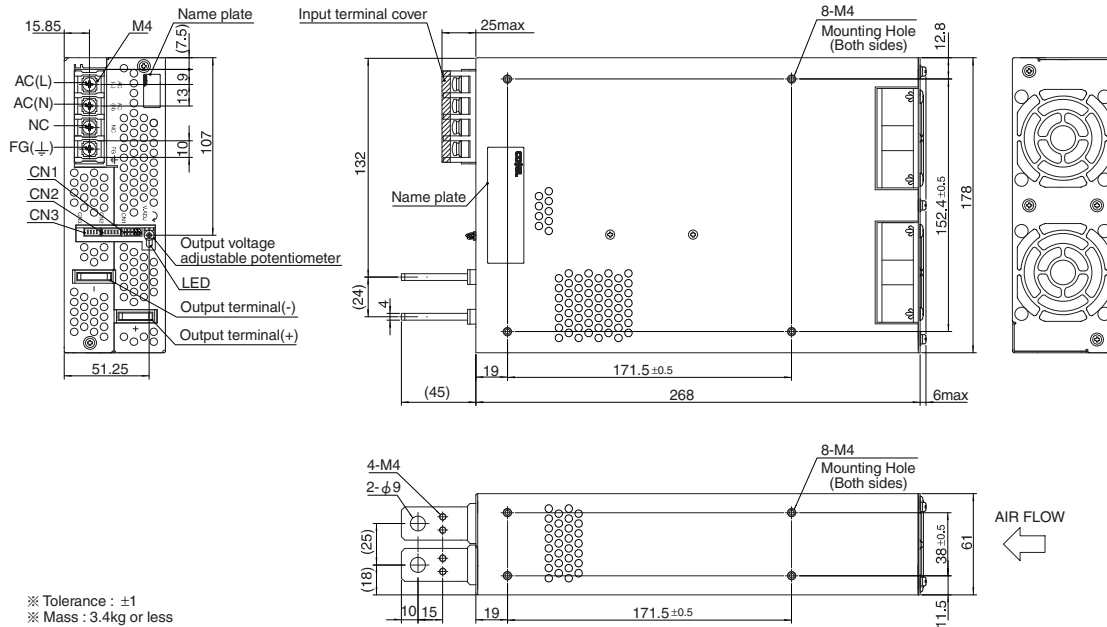

- ※ Tolerance : ±1
- ※ Mass : 3.4kg or less
- ※ PCB Material/thickness : FR-4 / 1.6mm
- ※ Chassis material : Aluminum
- ※ Dimensions in mm
- ※ Mounting torque : 1.2N · m(12.8kgf · cm)max
- ※ Screw tightening torque : 1.6N · m(16.9kgf · cm)max
- ※ The housing for the remote sensing unused is mounted on CN1
- ※ Please connect safety ground to FG terminal on the unit.